

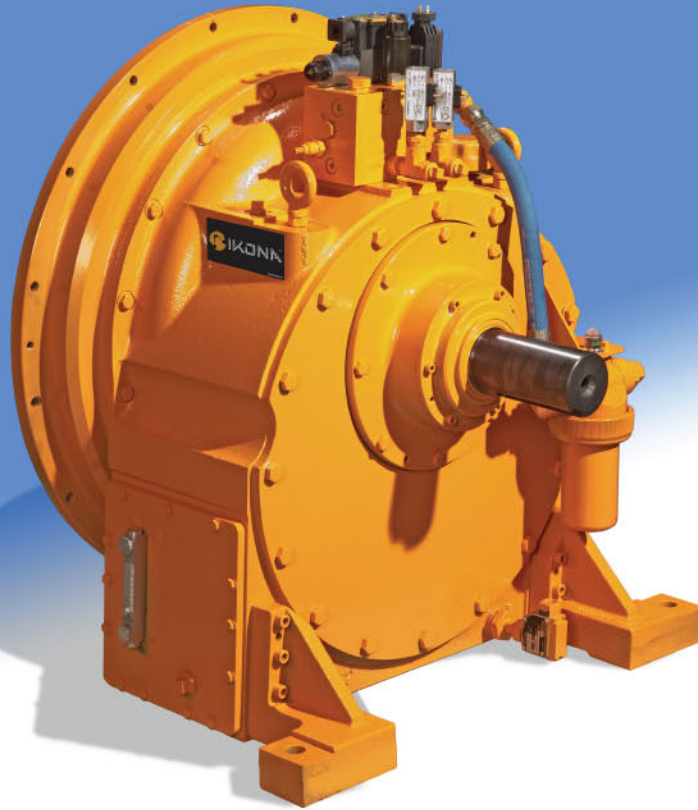

Hydraulic Power Take-Off

Ikona 1100HDC In-Line or Side Load



Features

- Smooth Engagement and Soft Start
- 50,000 Hours Overhaul Intervals
- Compact, Lightweight Design
- All Steel Torsional Coupling
- Self-Contained Oil Sump
- Use of Engine Oil for Lubrication
- High Speed Clutch Disengagement
- SAE Mounting Flange
- Multiple Control systems:
 - Mechanical
 - Electrical
 - Hydraulic
 - Pneumatic

IKONA Industries
Corporation

100 - 1650 Brigantine Dr.
Coquitlam, BC
Canada
V3K 7B5

tel: 604-523-5500
fax: 604-520-5965

www.ikona.ca

Hydraulic Power Take-Off

Ikona 1100HDC In-Line or Side Load

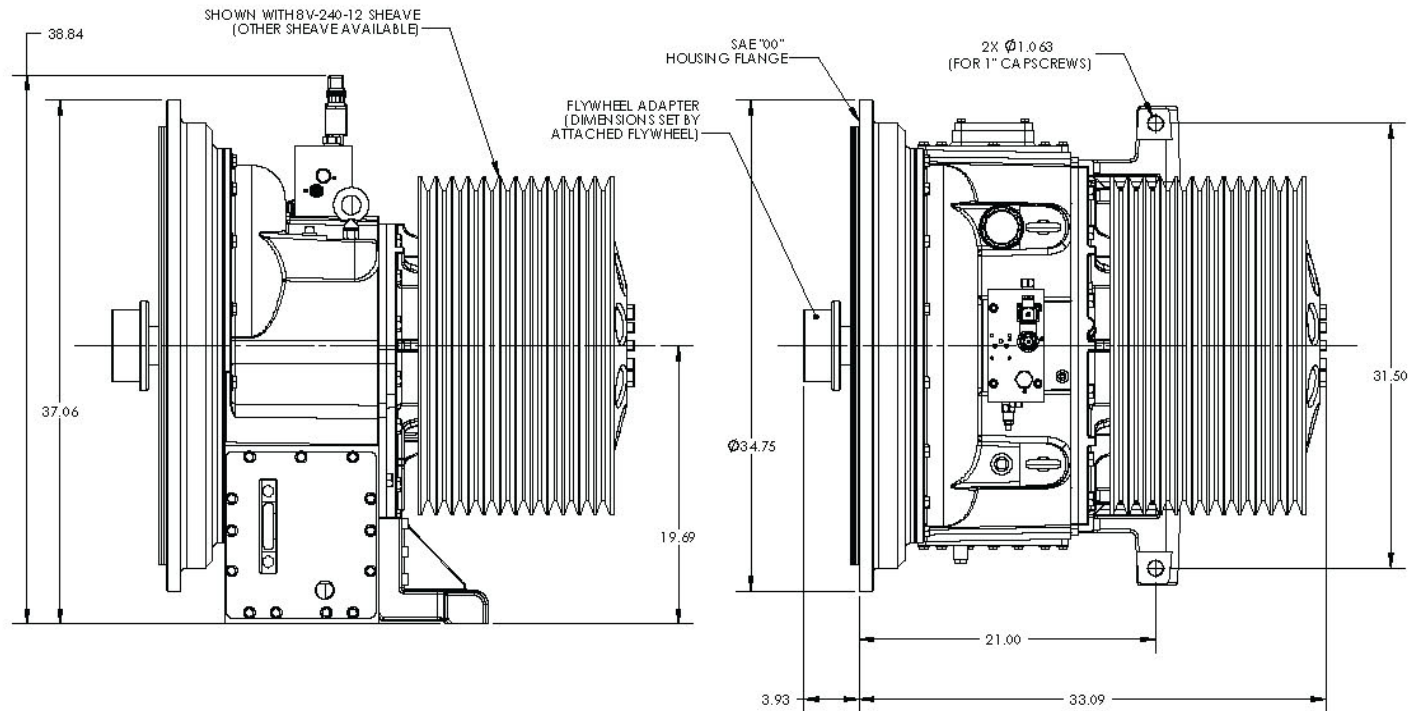

Dimensions subject to change.
Dimensions may vary according to application, ratio, etc.
Contact manufacturer or local representative for certified drawings.

Model

Ikona 1100HDC

Ratio

Direct Drive

Rating

up to
1,100 hp @ 1,200 rpm

Offset

N/A Coaxial Design

www.ikona.ca



IKONA
INDUSTRIES
CORPORATION